

WWW.JETINNOMACHINE.COM  
WWW.JETINNOVENDING.COM

**JETINNO**  
INSPIRE LIFE BETTER



Guangzhou Jetinno Intelligent Equipment Co., Ltd

Address: No. 220, Xiangli Road, Huangpu District, Guangzhou, China

Email: [inquiry@jetinno.com](mailto:inquiry@jetinno.com)

# PRODUCT CATALOG

# ABOUT US

Founded in 2013, JETINNO specializes in the research, design, and manufacturing of fully automatic coffee machines. We are committed to creating world-class coffee equipment with meticulous craftsmanship. Our fully automatic coffee machines are widely used in hotels, restaurants, cafés, convenience stores, vending, offices, and homes, ensuring that every cup of coffee delivers the perfect fusion of craftsmanship and technology.



INSPIRE LIFE BETTER



**20+ years**  
coffee machine expertise



**70,000m<sup>2</sup>**  
R&D and manufacturing base



**450+**  
employees



**260,000 Units**  
annual production capacity



**100+**  
R&D engineers



**16**  
coffee machine labs



**200+**  
patents & copyrights



**Sold in 100**  
countries and regions

# MILESTONES

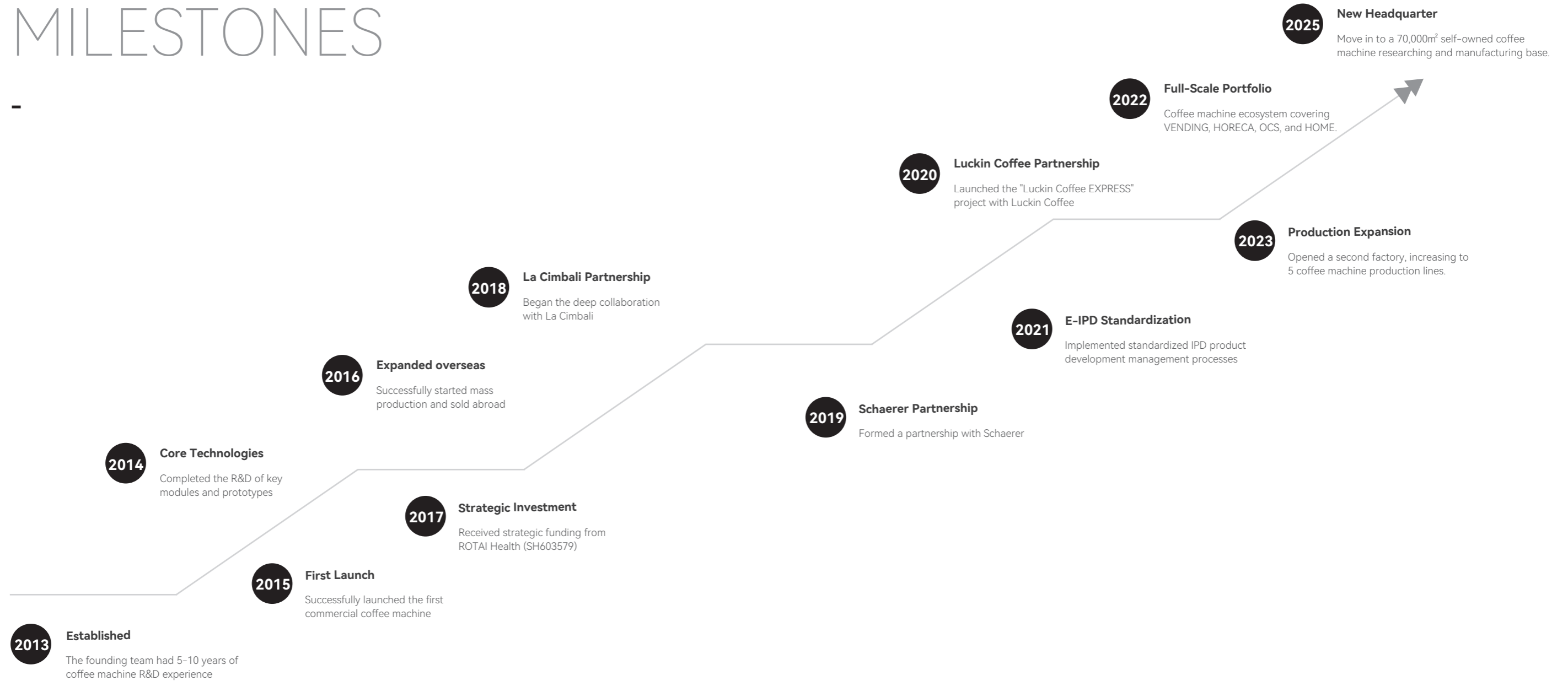

# MARKET

As of 2026, JETINNO's products are sold in over 100 countries and regions, earning the trust of more than 1000 global clients. With a strong reputation for quality and service, the company has built a global presence through over 50 distributors and actively participates in more than 30 international industry exhibitions each year to enhance brand influence.



**100**  
countries and regions

**1000+**  
global partners

**50+**  
global distributors

**30+**  
international exhibitions

## Overseas Partners

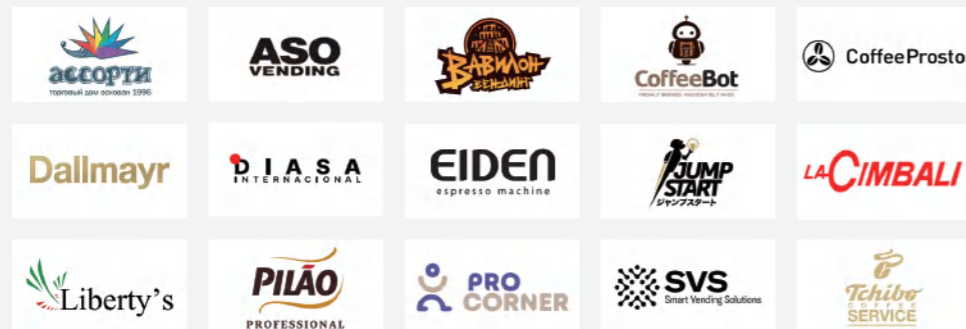

## Domestic Partners



# SERVICE

Jetinno upholds the service principles of integrity, reliability, responsibility, and efficiency, embedding them into every aspect of our operations—from product design and manufacturing to sales and after-sales service. This commitment ensures prompt, professional support and enhances customer satisfaction.



## Spare Parts

Order with free essential spare parts  
Efficient logistics to ensure quick and reliable delivery worldwide.  
Online parts catalog and ordering system

## Training

Product Training: product features, functionalities, and applications.  
Operation Training: Hands-on guidance on product usage and best practices.  
Repairing Training: Advanced troubleshooting and repair techniques to minimize downtime.

## Technical Support

Video call troubleshooting to solve problems in real time.  
On-Site in-person assistance when necessary.  
Professional support team commanding multiple languages.

# TECHNOLOGY

JETINNO's R&D Center is driven by a strong commitment to technological advancement, comprising 16 specialized coffee machine laboratories, which are officially authorized as witness laboratories by both SGS and TUV. Backed by a team of over 100 professional R&D engineers, the center has achieved more than 200 patents.



## Grinding System

High-precision 64mm special steel flat burrs for durability, adjustable grind size for uniform and fine coffee grounds.



## Brewing System

PCT international patent with advanced anti-gravity extraction and pre-wetting technology for optimal coffee flavor. Easily detachable brewer design.



## Milk Frothing System

Hot and cold milk frothing technologies. Precise milk temperature and density adjustment with automatic milk system cleaning.

**16**

Labs (SGS & TUV certified)

**200+**

Coffee Machine Patents

**100+**

R&D Engineers



## I-JETINNO Platform

Cloud-based SaaS management software enabling DIY drink customization, QR payments, remote machine monitoring, and data analytics.



## Self-Cleaning System

Automated cleaning for brewing system, mixing system, and milk system with scheduled cleaning for hygiene and easy maintenance.



## Automatic Cup & Lid System

Smart cup & lid dispensing with real-time monitoring and alerts for missing items. Supports 70/80/90mm paper cups/lids.



## Filter Brewer

Dual-purpose filter coffee & tea brewer with replaceable meshes. High-density filter holes prevent residue buildup, and quick disassembly ensures easy cleaning.

# TECHNOLOGY

JETINNO has independently developed core technologies for key commercial coffee machine components, forming a complete, self-sustained technology system.



## Grinding System



**Ditting EMH64 Grinder**

64mm flat burr (steel)  
650,000 grind cycles



**PGH64 Grinder**

Grinding speed: 2.0-3.8 g/s  
Motor lifespan: 125,000 cycles  
Burr lifespan: 500kg coffee beans



**SGH64 Grinder**

Grinding speed: 2.0-3.0 g/s  
Motor lifespan: 37,500 cycles  
Burr lifespan: 400-500kg coffee beans

## Espresso Brewers



**P14/20/22 Espresso Brewer**

Premium brewing system  
14g/20g/22g chamber options  
Lifespan: 80,000 cycles



**S14/20 Espresso Brewer**

Direct powder drop for even distribution  
14g/20g chamber options  
Lifespan: 40,000 cycles



**Filter Brewer**

Brewing chamber: 6-14g capacity  
High-temperature extraction at 90°C  
Pre-wetting and spray brewing technology

## Milk Frothing System



### FM Hot & Cold Milk/Froth System

Italy Fluid-o-tech professional milk pump  
Produces hot/cold milk froth and milk  
Customizable froth dryness, wetness, and temperature



### FV Hot Milk Frothing System

Produces hot milk and hot milk froth  
Froth temperature: 60°C-70°C  
Adjustable milk temperature

## Mixing System



### Powder Canister

Precise powder calibration and dispensing  
Anti-clogging design



### Mixer

Customizable mixing speed for recipe needs  
20,000 rpm for fast powder dissolution  
Dehumidification design

## Water System



### Hot Water Module

700mL high-pressure stainless steel boiler  
2700W high-power continuous hot water  
Sensors for real-time temperature/pressure monitoring  
Modular design for easy disassembly and maintenance  
Components sourced from top global suppliers



### Ice Maker

Ice production:  $\geq 4\text{kg/h}$  (1.2g mineral block ice)  
Continuous ice output:  $\geq 15$  cups (180g/cup)  
1.5kg ice bucket storage  
Smart alerts for water shortage, full ice, over-cooling, and low ice  
UV sterilization ice-making water system design

## Automatic Cup & Lid System



### Automatic Cup Dispensing Module

Five-cup bin design for 150 double-layer cups (90mm/160oz)  
Smart cup dispensing function



### Automatic Lid Dispensing Module

Single-cup bin design for 180 injection-molded lids (90mm)  
Smart lid dispensing function

# TECHNOLOGY

## I-Jetinno SaaS Platform

I-Jetinno is an advanced SaaS-based coffee machine management platform that helps coffee business operators streamline operations, reduce downtime, and maximize revenue.



### Comprehensive Equipment Management

Real-time machine status monitoring, including component functionality, material levels, and error reports.  
Remote control of machine settings, including beverage recipes, screen advertisements, and operational parameters.

### Automated Fault Detection & Maintenance

Intelligent system alerts for machine malfunctions, material shortages, and performance issues.  
Supports remote diagnostics and troubleshooting, minimizing downtime and maintenance costs.

### Sales & Transaction Analytics

Provides detailed sales reports, revenue tracking, and transaction records.  
Supports multi-dimensional analysis to optimize pricing, promotions, and product offerings.

### Multi-Channel Payment Integration

Compatible with QR code payments, credit card transactions, and mobile payment solutions.  
Ensures secure and seamless transactions while generating real-time financial reports.

### Cloud-Based Beverage & Recipe Management

Centralized platform for customizing and distributing beverage recipes across multiple machines.  
Ensures consistent drink quality and quick adaptation to market trends.

### Multi-Level Business & User Management

Hierarchical merchant account system for managing multiple locations under a single account.  
Customizable access permissions for different roles, ensuring secure and structured operations.

# PRODUCTION

## Craftsmanship and Intelligence

A quality-driven production center rigorously enforces quality from inception, implements comprehensive testing protocols, strictly adheres to ISO quality management standards, ensuring consistently stable and efficient performance in every coffee machine.



## Automated Assembly

Industry-first Fully Automated Module Assembly Lines for Grinders, Brewers, and Mixers

## 8 Coffee Machine Lines

6 dedicated lines and 2 flexible lines

## 70,000m<sup>2</sup>

Intelligent Coffee Machine Manufacturing Base

## 260,000 Units

Annual Production Capacity



### Core Module Automated Assembly

Three automated lines for Grinder, Brewer and Mixer modules. 90% automation with annual capacity of 400,000 modules per line.

### Smart Warehouse System

Integrated ERP, WMS and RCS robotic control for digital warehouse management. 21 AGV robots enable automatic picking and material delivery.

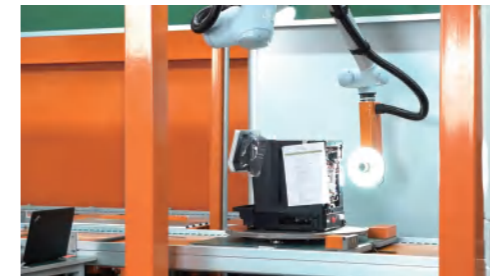

### AI Vision Inspection

Three AI inspection checkpoints on each production line. Detects assembly errors, appearance defects, and missing accessories.

### 100% Beverage Testing

Every machine tested with real coffee beans and fresh milk. 40+ parameters automatically recorded for quality traceability.



# PRODUCTS



01

Home



02

OCS-FM

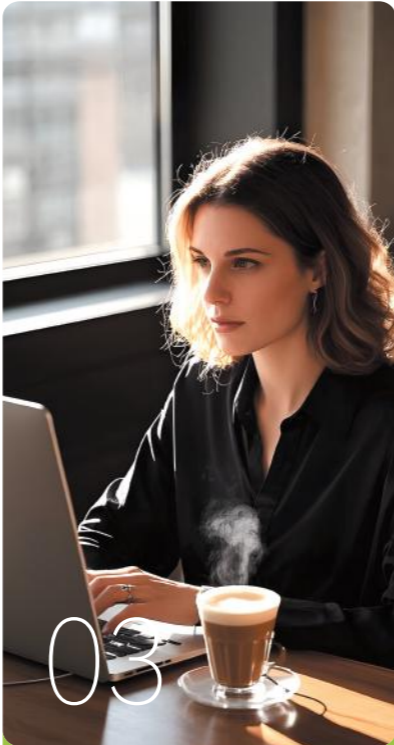

03

OCS-PM



04

Ho.Re.Ca



05

Vending



06

Coffee to Go

**Home**

**OCS-FM**

**OCS-PM**

**Ho.Re.Ca**

**Vending**

**Coffee to Go**

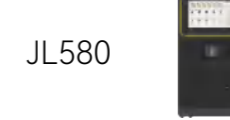
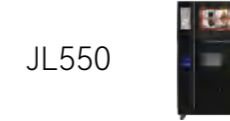
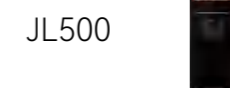
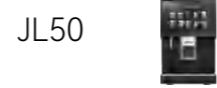
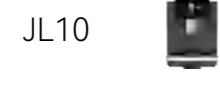
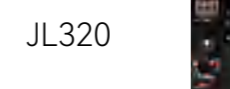
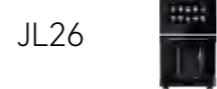
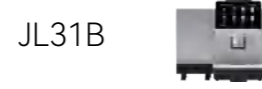
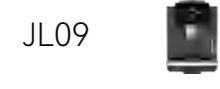
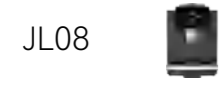
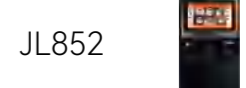
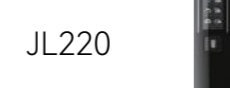
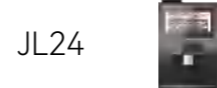
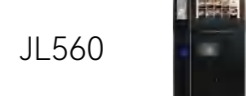
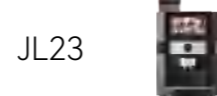
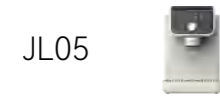
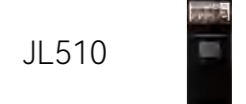
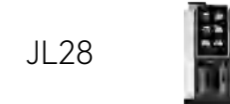
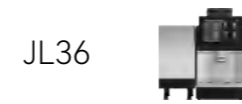
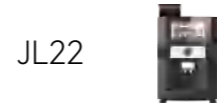
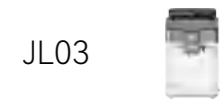



Equipped with commercial-grade grinding and brewing system, ensuring premium coffee quality in every cup. Featuring a sleek design, smart controls, and user-friendly operation, it allows you to craft barista-quality coffee in your own house.



# JL03

CCC CE CB

Daily Output:  
**10 Cups**

Colors:  
●

Optional Accessory:  
**Milk Tank**



### Professional Brewing System

Compatible with 14g and 20g brewers for most coffee recipes, dual hot & cold extraction for varied flavors, and a detachable brewer for easy cleaning and hygiene.



### Smart APP Control

Allows remote ordering via mobile app, personalized coffee customization, and saving preferences for a tailor-made coffee experience.



### Hassle-Free Bean Management

500g large-capacity bean hopper reduces refill frequency, easy-detach design makes refilling and cleaning effortless, plus smart bean detection ensures you're never caught short.

| Model        | Power | Dimensions             | Net Weight | Grinder   | Brewer               | Heating         | Pump            | Milk System  |
|--------------|-------|------------------------|------------|-----------|----------------------|-----------------|-----------------|--------------|
| <b>JL03A</b> | 1600W | 243(W)*416(H)*470(D)mm | 9.5kg      | SGH64 x 1 | S20x1/S14 (optional) | Thermoblock x 1 | Piston pump x 1 | —            |
| <b>JL03B</b> | 1600W | 243(W)*416(H)*470(D)mm | 10kg       | SGH64 x 1 | S20x1/S14 (optional) | Thermoblock x 1 | Piston pump x 1 | Milk frother |
| <b>JL03C</b> | 1600W | 243(W)*416(H)*470(D)mm | 10.5kg     | SGH64 x 1 | S20x1/S14 (optional) | Thermoblock x 1 | Piston pump x 1 | —            |

| Steam Wand | Spout Height | Bean Hopper           | Water Tank | Drip Tray | Waste Bin     |
|------------|--------------|-----------------------|------------|-----------|---------------|
| —          | 100-140mm    | 400g x 1,(detachable) | 1.45L      | 0.6L      | 10 cakes (8g) |
| —          | 100-140mm    | 400g x 1,(detachable) | 1.45L      | 0.6L      | 10 cakes (8g) |
| ✓          | 100-140mm    | 400g x 1,(detachable) | 1.45L      | 0.6L      | 10 cakes (8g) |



JL05

CCC CE CB

Daily Output:  
**10 Cups**

Colors:



Optional Accessory:  
**Milk Tank**



**Commercial-Grade Grinding & Brewing**

Equipped with patented SGH64 commercial grinder and S14 espresso brewer, ensuring professional stability and authentic coffee flavor in every cup.



**Smart APP Control**

Allows remote ordering via mobile app, personalized coffee customization, and saving preferences for a tailor-made coffee experience.



**Adjustable Coffee Strength**

Manual knob for coffee strength adjustment to suit different taste preferences, ensuring every cup is perfectly tailored to your taste.

| Model        | Power | Dimensions             | Net Weight | Grinder   | Brewer  | Heating         | Pump            | Milk System  |
|--------------|-------|------------------------|------------|-----------|---------|-----------------|-----------------|--------------|
| <b>JL05A</b> | 1600W | 240(W)*360(H)*450(D)mm | 9.5kg      | SGH64 x 1 | S14 x 1 | Thermoblock x 1 | Piston pump x 1 | —            |
| <b>JL05B</b> | 1600W | 240(W)*360(H)*450(D)mm | 10kg       | SGH64 x 1 | S14 x 1 | Thermoblock x 1 | Piston pump x 1 | Milk frother |
| <b>JL05C</b> | 1600W | 240(W)*360(H)*450(D)mm | 10.5kg     | SGH64 x 1 | S14 x 1 | Thermoblock x 1 | Piston pump x 1 | —            |

| Steam Wand | Spout Height | Bean Hopper | Water Tank | Drip Tray | Waste Bin     |
|------------|--------------|-------------|------------|-----------|---------------|
| —          | 80-140mm     | 200g x 1    | 1.6L       | 0.6L      | 10 cakes (8g) |
| —          | 80-140mm     | 200g x 1    | 1.6L       | 0.6L      | 10 cakes (8g) |
| √          | 80-140mm     | 200g x 1    | 1.6L       | 0.6L      | 10 cakes (8g) |



JL06

CCC CE CB

Daily Output:  
**10 Cups**

Colors:  
● ●

Optional Accessory:  
**Milk Tank**



**Innovative Design**

Crafted by Italian designers with a stylish and distinctive look. Features a curved menu interface for an intuitive and user-friendly experience.



**Cold Brew Coffee**

Fast cold brew technology delivers smooth, naturally sweet cold brew coffee in just 5 minutes, preserving the original flavor and aroma of the coffee.



**Detachable Brewer for Easy Cleaning**

Smartly designed brewing unit allows for quick disassembly and easy cleaning, ensuring a consistently hygienic machine interior.

| Model        | Power | Dimensions             | Net Weight | Grinder   | Brewer  | Heating         | Pump            | Milk System  |
|--------------|-------|------------------------|------------|-----------|---------|-----------------|-----------------|--------------|
| <b>JL06A</b> | 1600W | 240(W)*360(H)*450(D)mm | 9.5kg      | SGH64 x 1 | S14 x 1 | Thermoblock x 1 | Piston pump x 1 | —            |
| <b>JL06B</b> | 1600W | 240(W)*360(H)*450(D)mm | 10kg       | SGH64 x 1 | S14 x 1 | Thermoblock x 1 | Piston pump x 1 | Milk frother |
| <b>JL06C</b> | 1600W | 240(W)*360(H)*450(D)mm | 10.5kg     | SGH64 x 1 | S14 x 1 | Thermoblock x 1 | Piston pump x 1 | —            |

| Steam Wand | Spout Height | Bean Hopper | Water Tank | Drip Tray | Waste Bin     |
|------------|--------------|-------------|------------|-----------|---------------|
| —          | 80-140mm     | 200g x 1    | 1.6L       | 0.6L      | 10 cakes (8g) |
| —          | 80-140mm     | 200g x 1    | 1.6L       | 0.6L      | 10 cakes (8g) |
| √          | 80-140mm     | 200g x 1    | 1.6L       | 0.6L      | 10 cakes (8g) |



JL10



Daily Output:  
**30 Cups**

Colors:



Optional Accessory:  
**Milk Tank / Fresh Milk Fridge**



**Professional Coffee Extraction**

Equipped with JETINNO's patented S14 brewer (optional S20), featuring high-pressure espresso extraction for precise control over the brewing process, ensuring consistent coffee quality in every cup.



**Beverage Customization**

Advanced backend settings allow users to fully customize their drinks, offering endless customization possibilities to satisfy coffee enthusiasts' desire for exploration.



**Smart Auto-Cleaning**

One-touch automatic cleaning for the brewer and fresh milk system, ensuring effortless maintenance and hygiene.

| Model | Power | Dimensions             | Net Weight | Grinder   | Brewer               | Heating         | Pump            | Milk System  |
|-------|-------|------------------------|------------|-----------|----------------------|-----------------|-----------------|--------------|
| JL08  | 1700W | 300(W)*440(H)*490(D)mm | 15kg       | SGH64 x 1 | S14x1/S20 (optional) | Thermoblock x 1 | Piston pump x 1 | —            |
| JL09  | 1700W | 300(W)*440(H)*490(D)mm | 15kg       | SGH64 x 1 | S14x1/S20 (optional) | Thermoblock x 1 | Piston pump x 1 | —            |
| JL10  | 1700W | 300(W)*440(H)*490(D)mm | 15kg       | SGH64 x 1 | S14x1/S20 (optional) | Thermoblock x 1 | Piston pump x 1 | Milk frother |

| Steam Wand | Drip Tray | Bean Hopper | Daily Output | Water Tank  | Waste Bin      |
|------------|-----------|-------------|--------------|-------------|----------------|
| —          | 0.7L      | 500g x 1    | 30           | 2L, Opt. 8L | 40 cakes (10g) |
| ✓          | 0.7L      | 500g x 1    | 30           | 2L, Opt. 8L | 40 cakes (10g) |
| —          | 0.7L      | 500g x 1    | 30           | 2L, Opt. 8L | 40 cakes (10g) |



Combining high-efficiency grinding with professional espresso extraction, OCS-FM machines precisely unlocks the bold, aromatic flavors of coffee while delivering a smooth, well-rounded taste. The innovative fresh milk system creates smooth, velvety milk foam that blends perfectly with coffee for a creamy, indulgent experience. With intelligent auto-cleaning and detachable components, maintenance is more convenient and efficient.



## JL15

CCC CE CB

Daily Output: **60 Cups**  
 Colors: ● ○  
 Optional Accessory: **Fresh Milk Fridge**



## JL30

CQC CE CB

Daily Output: **100 Cups**  
 Colors: ○ ●  
 Optional Accessory: **Fresh Milk Fridge**



## JL29B

CQC CE CB

Daily Output: **100 Cups**  
 Colors: ○ ●



### Professional Espresso Extraction

Equipped with patented S14 brewer (optional S20), delivering high-pressure espresso extraction with rich crema, ensuring premium beverage quality for every cup.



### Detachable Designs for Optimal Hygiene

The brewing unit and nozzle can be detached in seconds, keeping the machine interior consistently clean and hygienic.



### Smart Bean Shortage Detection

Intelligent bean shortage alerts to ensure timely refilling, optimizing operational efficiency.



| Model        | Power | Dimensions             | Net Weight | Grinder   | Brewer               | Heating         | Pump            | Milk System  |
|--------------|-------|------------------------|------------|-----------|----------------------|-----------------|-----------------|--------------|
| <b>JL15</b>  | 1700W | 300(W)*440(H)*490(D)mm | 16kg       | SGH64 x 1 | S14x1/S20 (optional) | Thermoblock x 2 | Piston pump x 1 | Milk frother |
| <b>JL29B</b> | 1700W | 300(W)*548(H)*490(D)mm | 16kg       | SGH64 x 1 | S14x1/S20 (optional) | Thermoblock x 1 | Piston pump x 1 | —            |
| <b>JL30</b>  | 1700W | 300(W)*548(H)*490(D)mm | 17kg       | SGH64 x 1 | S14x1/S20 (optional) | Thermoblock x 2 | Piston pump x 1 | Milk frother |

| Screen Type     | Spout Height | Drip Tray                      | Bean Hopper | Water Tank  | Waste Bin                                      |
|-----------------|--------------|--------------------------------|-------------|-------------|--|
| 7" touch screen | 80-160mm     | 0.7L                           | 500g x 1    | 2L, Opt. 8L | 40 cakes (10g)                                 |
| 7" touch screen | 80-160mm     | 1L, direct drainage (optional) | 1200g x 1   | 2L, Opt. 8L | 50 cakes (10g), direct slagging off (optional) |
| 7" touch screen | 80-160mm     | 1L, direct drainage (optional) | 1200g x 1   | 2L, Opt. 8L | 50 cakes (10g), direct slagging off (optional) |



# JL31A

CQC CE CB

Daily Output:  
100 Cups

Colors:  
● ●

Optional Accessory:  
Fresh Milk Fridge



# JL31B

CQC CE CB

Daily Output:  
100 Cups

Colors:  
● ●

Optional Accessory:  
Fresh Milk Fridge



### Dual Pump & Dual Boiler

High-efficiency dual pump and dual boiler design enables simultaneous coffee and milk preparation, improving beverage production speed and reducing wait times—perfect for handling peak hours with ease.



### Versatile Water Supply Options

Built-in 2L water tank (optional 8L), compatible with barreled water and direct tap water. Three flexible water supply options to suit different operational needs.



### Hot Water Spout

Equipped with a dedicated hot water spout for one-touch dispensing, ensuring convenience and efficiency.

| Model | Power | Dimensions             | Net Weight | Grinder   | Brewer               | Heating         | Pump            | Milk System  |
|-------|-------|------------------------|------------|-----------|----------------------|-----------------|-----------------|--------------|
| JL31A | 2850W | 300(W)*548(H)*490(D)mm | 18kg       | SGH64 x 1 | S14x1/S20 (optional) | Thermoblock x 2 | Piston pump x 2 | Milk frother |
| JL31B | 2850W | 300(W)*548(H)*490(D)mm | 19kg       | SGH64 x 1 | S14x1/S20 (optional) | Thermoblock x 2 | Piston pump x 2 | Milk frother |

| Screen Type        | Hot Water Spout | Drip Tray                      | Bean Hopper | Water Tank  | Waste Bin                                      |
|--------------------|-----------------|--------------------------------|-------------|-------------|--|
| 7" touch screen    | ✓               | 1L, direct drainage (optional) | 1200g x 1   | 2L, Opt. 8L | 50 cakes (10g), direct slugging off (optional) |
| 10.1" touch screen | ✓               | 1L, direct drainage (optional) | 1200g x 1   | 2L, Opt. 8L | 50 cakes (10g), direct slugging off (optional) |



A fully automatic freshly ground coffee machine equipped with professional grinding and extraction systems to ensure consistent, high-quality coffee in high-demand environments. Its multi-mix canister design offers a variety of coffee flavors and instant beverage options.



JL22/23

CQC CE CB

Daily Output:  
**150 Cups**

Colors:



Optional Accessory:  
**Base Cabinet**



**Advanced Brewing System**

Equipped with a high-performance P14 brewer (optional P20) and a 2700W water boiler and gear pump (JL23), ensuring stable 9-bar pressure and 92°C optimal extraction for consistently exceptional beverage quality.



**Compact Design**

Sleek and space-saving, designed to fit into limited spaces while seamlessly integrating into various commercial environments.



**10+ Beverage Options**

Multi-canister design enables the preparation of a wide range of drinks, including black coffee, milk-based coffee, and instant beverages, catering to diverse consumer preferences.

| Model            | Power | Dimensions             | Net Weight | Grinder         | Brewer                   | Heating    | Pump            |
|------------------|-------|------------------------|------------|-----------------|--------------------------|------------|-----------------|
| <b>JL22-ES4C</b> | 2800W | 400(W)*675(H)*550(D)mm | 42kg       | PGH64 x 1       | P14x1/P20/P22 (optional) | Boiler x 1 | Piston pump x 1 |
| <b>JL22-IN5C</b> | 2800W | 400(W)*580(H)*550(D)mm | 40kg       | —               | —                        | Boiler x 1 | Piston pump x 1 |
| <b>JL23-ES4C</b> | 2800W | 400(W)*667(H)*550(D)mm | 42kg       | Ditting EK7 x 1 | P14x1/P20/P22 (optional) | Boiler x 1 | Gear pump x 1   |

| Mixer               | Screen Type        | Spout Height | Drip Tray                        | Bean Hopper | Instant Canister | Waste Bin                               |
|---------------------|--------------------|--------------|----------------------------------|-------------|------------------|---|
| 2                   | 10.1" touch screen | 80-115mm     | 1.5L, direct drainage (optional) | 1.5kg x 1   | 1.5L x 3         | 50 cakes direct slagging off (optional) |
| 3pcs 4pcs(optional) | 10.1" touch screen | 80-115mm     | 1.5L, direct drainage (optional) | —           | 1.5L x 5         | —                                       |
| 2                   | 10.1" touch screen | 80-115mm     | 1.5L, direct drainage (optional) | 1.5kg x 1   | 1.5L x 3         | 50 cakes direct slagging off (optional) |



JL24

CQC CE CB

Daily Output:  
**150 Cups**

Colors:



Optional Accessory:  
**Base Cabinet**

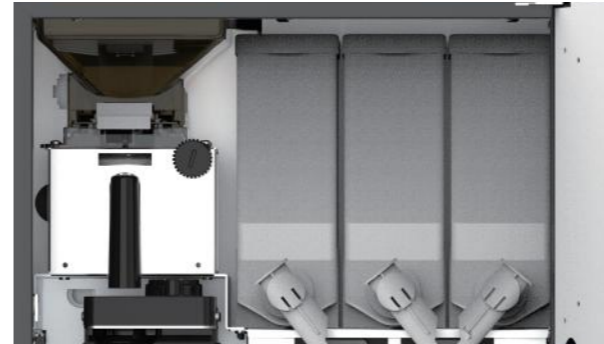

**Large Capacity Design**

The larger mix canister capacity reduces the need for frequent refills, making it ideal for high-usage, space-limited office or commercial environments.



**14-Inch Touchscreen**

The 14-inch touchscreen, combined with an intuitive Android OS, provides easy self-ordering on the front end and seamless equipment management on the back end, enhancing both user experience and operational efficiency.



**Enhanced Performance**

The efficient dehumidification system prevents instant powder from clumping, while the machine's excellent sealing design keeps insects out, ensuring the hygiene and safety of every beverage and guaranteeing premium quality in each cup.

| Model            | Power | Dimensions             | Net Weight | Grinder   | Brewer                   | Heating    | Pump            |
|------------------|-------|------------------------|------------|-----------|--------------------------|------------|-----------------|
| <b>JL24-ES4C</b> | 2800W | 420(W)*740(H)*535(D)mm | 45kg       | PGH64 x 1 | P14x1/P20/P22 (optional) | Boiler x 1 | Piston pump x 1 |
| <b>JL24-IN5C</b> | 2800W | 420(W)*671(H)*535(D)mm | 42kg       | —         | —                        | Boiler x 1 | Piston pump x 1 |

| Mixer               | Screen Type      | Spout Height | Drip Tray                        | Bean Hopper | Instant Canister | Waste Bin                               |
|---------------------|------------------|--------------|----------------------------------|-------------|------------------|---|
| 2                   | 14" touch screen | 80-120mm     | 1.5L, direct drainage (optional) | 1.5kg x 1   | 2L x 3           | 50 cakes direct slagging off (optional) |
| 3pcs 4pcs(optional) | 14" touch screen | 80-120mm     | 1.5L, direct drainage (optional) | —           | 2L x 5           | —                                       |



# JL18

CQC CE CB

Daily Output:  
**250 Cups**

Colors:



Optional Accessory:  
**Base Cabinet**



### Precise Grinding

Equipped with the Ditting EMH64 professional grinder, offering precise and efficient grinding, providing solid hardware support for high-quality coffee output and quick cup delivery.



### Premium Coffee Brewer

Featuring the high-performance P14 brewer (optional P20) and a 2700W boiler and powerful gear pump, ensuring efficient and stable 9-bar pressure and 92°C optimal extraction for premium coffee quality.



### 14-Inch Vertical Screen

Compact body with a 14-inch vertical screen, offering powerful performance in a small form factor, ideal for various commercial environments.

| Model             | Power | Dimensions             | Net Weight | Grinder                                      | ES Brewer                   | Filter Brewer   | Heating    | Pump            |
|-------------------|-------|------------------------|------------|--|-----------------------------|-----------------|------------|-----------------|
| <b>JL18-ES3C</b>  | 2600W | 310(W)*713(H)*482(D)mm | 40.5kg     | Ditting EMH64 x1<br>Jetinno PGH64 (optional) | P14x1/P20/P22<br>(optional) | —               | Boiler x 1 | Gear pump x 1   |
| <b>JL18-BTC3C</b> | 2600W | 310(W)*713(H)*482(D)mm | 40.5kg     | Ditting EMH64 x1<br>Jetinno PGH64 (optional) | —                           | 14g x 1(coffee) | Boiler x 1 | Piston pump x 1 |

| Mixer | Screen Type      | Hot Water Spout | Drip Tray                           | Bean Hopper | Instant Canister   | Waste Bin                                  |
|-------|------------------|-----------------|-------------------------------------|-------------|--------------------|--|
| 1     | 14" touch screen | ✓               | 1.3L, direct drainage<br>(optional) | 1.8kg x 1   | 3.5L x 1 +2.3L x 1 | 50 cakes<br>direct slagging off (optional) |
| 1     | 14" touch screen | ✓               | 1.3L, direct drainage<br>(optional) | 1.8kg x 1   | 3.5L x 1 +2.3L x 1 | 50 cakes<br>direct slagging off (optional) |



JL26

CQC CE CB

Daily Output:  
**250 Cups**

Colors:



Optional Accessory:  
**Base Cabinet**

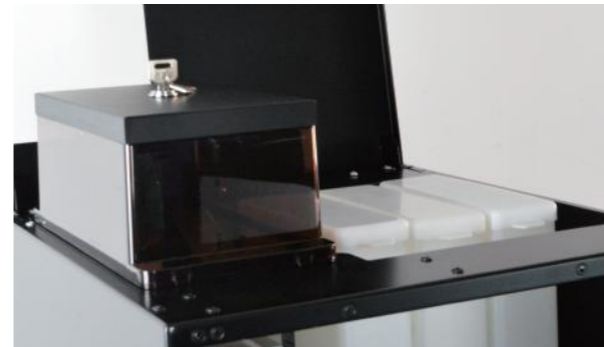

**Efficient Grinding**

Equipped with the Ditting EMH64 professional grinder, ensuring precise and efficient grinding for fast and high-quality coffee output.



**Large Capacity Design**

The expanded canister capacity reduces the need for frequent refills, making it ideal for high-usage, space-limited office or commercial environments.



**Multi-Canister Design**

1 bean hopper and 3 instant canisters, capable of preparing over 10 different types of coffee and instant beverages to meet diverse consumer needs.

| Model              | Power | Dimensions             | Net Weight | Grinder           | ES Brewer                | Filter Brewer   | Heating    | Pump            |
|--------------------|-------|------------------------|------------|-------------------|--------------------------|-----------------|------------|-----------------|
| <b>JL26-ES4C</b>   | 2600W | 420(W)*808(H)*520(D)mm | 50kg       | Ditting EMH64 x 1 | P14x1/P20/P22 (optional) | —               | Boiler x 1 | Gear pump x 1   |
| <b>JL26-ESFB4C</b> | 2600W | 420(W)*808(H)*520(D)mm | 50kg       | Ditting EMH64 x 1 | P14x1/P20/P22 (optional) | 14g x 1(tea)    | Boiler x 1 | Gear pump x 1   |
| <b>JL26-BTC4C</b>  | 2600W | 420(W)*808(H)*520(D)mm | 50kg       | Ditting EMH64 x 1 | —                        | 14g x 1(coffee) | Boiler x 1 | Piston pump x 1 |

| Mixer | Screen Type      | Hot Water Spout | Drip Tray                        | Bean Hopper | Instant Canister | Waste Bin                               |
|-------|------------------|-----------------|----------------------------------|-------------|------------------|---|
| 2     | 14" touch screen | ✓               | 1.5L, direct drainage (optional) | 1.5kg x 1   | 2L x 3           | 80 cakes direct slagging off (optional) |
| 1     | 14" touch screen | ✓               | 1.5L, direct drainage (optional) | 1.5kg x 1   | 2L x 3           | 80 cakes direct slagging off (optional) |
| 2     | 14" touch screen | ✓               | 1.5L, direct drainage (optional) | 1.5kg x 1   | 2L x 3           | 80 cakes direct slagging off (optional) |



# JL26B

CE CB

Daily Output:  
**200 Cups**

Colors:  
●

Optional Accessory:  
**Base Cabinet**



### High-Capacity Design

1.8kg bean hopper and three 3L powder canisters reduce refill frequency and minimize maintenance needs.



### Advanced IoT Technology

Powered by a SaaS coffee machine control platform for remote device management, promotions, and operational data analysis.



### Expandable Configuration

Compatible with Jetinno JA10 automatic cup dispenser and JA30 ice maker to form a more powerful product suite.

| Model        | Power | Dimensions             | Net Weight | Grinder   | ES Brewer | Mixer | Heating    | Pump            |
|--------------|-------|------------------------|------------|-----------|-----------|-------|------------|-----------------|
| <b>JL26B</b> | 2900W | 420(W)*840(H)*520(D)mm | 50kg       | PGH64 x 1 | P20x1     | 2     | Boiler x 1 | Piston pump x 1 |

| Screen Type      | Spout Height | Drip Tray                        | Bean Hopper | Instant Canister    | Waste Bin                                |
|------------------|--------------|----------------------------------|-------------|---------------------|--|
| 14" touch screen | 180mm        | 1.5L, direct drainage (optional) | 1.8kg x 1   | 3L x 3, opt. 2L x 3 | 100 cakes direct slagging off (optional) |



# JL26C

CE CB

Daily Output:  
**200 Cups**

Colors:  
●

Optional Accessory:  
**Base Cabinet**

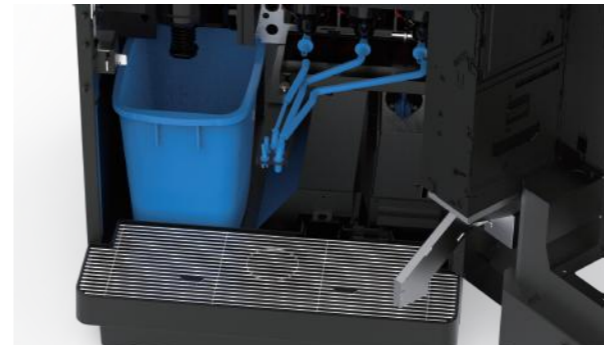

### Extended Capability

Lockable bean hopper with extended capacity of 4kg and 4 large instant canisters provide versatile beverage options and reduce maintenance frequency.



### Flexible Waste Handling

2.6L drip tray with optional direct drainage and 8L waste bin with optional direct slugging off.



### SaaS Management

Remote control for recipes, ads, and system upgrades. Real-time malfunction alerts and comprehensive sales data analytics.

| Model        | Power | Dimensions             | Net Weight | Grinder   | ES Brewer | Mixer | Heating    | Pump            |
|--------------|-------|------------------------|------------|-----------|-----------|-------|------------|-----------------|
| <b>JL26C</b> | 2900W | 480(W)*875(H)*600(D)mm | 65kg       | PGH64 x 1 | P14x1     | 3     | Boiler x 1 | Piston pump x 1 |

| Screen Type        | Payment Method                         | Drip Tray                        | Bean Hopper | Instant Canister | Waste Bin                                    |
|--------------------|--|----------------------------------|-------------|------------------|--|
| 15.6" touch screen | MDB Protocol, opt. coin, card, QR code | 2.6L, direct drainage (optional) | 4.8kg x 1   | 2L x 2 + 4L x 2  | 180~200 cakes direct slugging off (optional) |



JL50

CE CB

Daily Output:  
**250 Cups**

Colors:



Optional Accessory:  
**Base Cabinet**

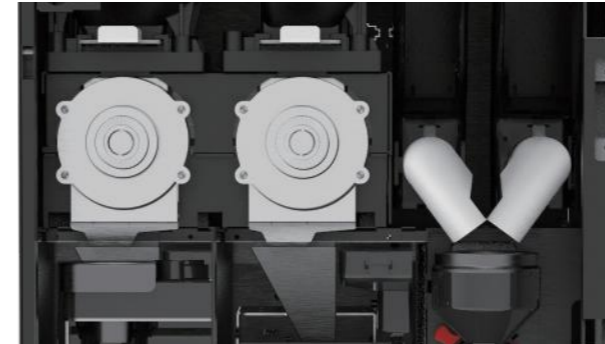

**Dual Grinder and Dual Brewers**

Dual bean hoppers, dual grinders, and dual brewing systems allow for two different coffee beans, enhancing both performance and efficiency.



**Strong and Stable Performance**

Equipped with commercial-grade components, including 2700W boiler and gear pump, significantly improving efficiency and stability, ensuring fast beverage delivery even during peak hours.



**Diverse Beverage Options**

Featuring dual bean hoppers and 2.3L + 3.5L canisters, capable of preparing over 10 different types of coffee and instant beverages.

| Model        | Power | Dimensions             | Net Weight | Grinder           | ES Brewer                | Filter Brewer   | Heating    | Pump          |
|--------------|-------|------------------------|------------|-------------------|--------------------------|-----------------|------------|---------------|
| <b>JL50A</b> | 2800W | 365(W)*750(H)*535(D)mm | 60kg       | Ditting EMH64 x 2 | P14x2/P20/P22 (optional) | —               | Boiler x 1 | Gear pump x 1 |
| <b>JL50B</b> | 2800W | 365(W)*750(H)*535(D)mm | 60kg       | Ditting EMH64 x 2 | P14x1/P20/P22 (optional) | 14g x 1(coffee) | Boiler x 1 | Gear pump x 1 |

| Mixer | Screen Type      | Hot Water Spout | Drip Tray                      | Bean Hopper | Instant Canister | Waste Bin                               |
|-------|------------------|-----------------|--------------------------------|-------------|------------------|---|
| 1     | 14" touch screen | ✓               | 1L, direct drainage (optional) | 5Lx1+2.8Lx1 | 2.3L x1 +3.5L x1 | 80 cakes direct slagging off (optional) |
| 1     | 14" touch screen | ✓               | 1L, direct drainage (optional) | 5Lx1+2.8Lx1 | 2.3L x1 +3.5L x1 | 80 cakes direct slagging off (optional) |



Designed for commercial establishments, Ho.Re.Ca machines feature professional high-efficiency grinding and stable high-pressure extraction, delivering rich and intense espresso flavors. The advanced fresh milk system creates dense, creamy milk foam for a smooth and refined taste. Smart operation supports one-touch brewing, remote management, and auto-cleaning, making it an ideal solution for high-quality coffee service in business settings.



# JL36

CQC CE CB

Daily Output:  
**100 Cups**

Colors:



Optional Accessory:  
**Fresh Milk Fridge / Base Cabinet**



### Stylish Design

Expertly crafted by Italian designers, featuring a 10.1-inch touchscreen, mirror-finish stainless steel front panel, and three-color breathing lights, highlighting its premium feel.



### Smart Auto-Cleaning

Innovative automatic milk system cleaning function with one-touch cleaning and no manual intervention required. The intelligent timed cleaning feature ensures worry-free maintenance.



### Removable Bean Hopper

The bean hopper can be easily removed with one touch, allowing for quick bean changes to cater to different flavor preferences and enhancing user convenience.

| Model        | Power | Dimensions             | Net Weight | Grinder   | ES Brewer            | Heating         | Pump            | Milk System  |
|--------------|-------|------------------------|------------|-----------|----------------------|-----------------|-----------------|--------------|
| <b>JL36A</b> | 3500W | 300(W)*585(H)*512(D)mm | 22kg       | SGH64 x 1 | S14x1/S20 (optional) | Thermoblock x 2 | Piston pump x 2 | Milk frother |
| <b>JL36B</b> | 1900W | 300(W)*585(H)*512(D)mm | 20kg       | SGH64 x 1 | S14x1/S20 (optional) | Thermoblock x 1 | Piston pump x 1 | —            |

| Screen Type        | Spout Height | Drip Tray                        | Bean Hopper | Water Tank  | Waste Bin                                     |
|--------------------|--------------|----------------------------------|-------------|-------------|---|
| 10.1" touch screen | 105-180mm    | 1.2L, direct drainage (optional) | 1200g x 1   | 2L, Opt. 8L | 70 cakes (10g) direct slagging off (optional) |
| 10.1" touch screen | 105-180mm    | 1.2L, direct drainage (optional) | 1200g x 1   | 2L, Opt. 8L | 70 cakes (10g) direct slagging off (optional) |



JL37

CQC CE CB

Daily Output:  
**200 Cups**

Colors:

Optional Accessory:  
**Fresh Milk Fridge / Base Cabinet****Golden Extraction Quality**

Dual-boiler system with a reheating boiler compensates for heat loss in the pipeline, ensuring optimal temperature stability for perfect coffee extraction.

**Hot & Cold Milk Foam**

Equipped with a professional milk pump and frother to create dense, silky milk foam for both hot and cold beverages.

**Professional Steam Wand**

Powerful and stable steam output allows simultaneous coffee extraction and milk steaming for efficient, café-grade performance.

| Model        | Power | Dimensions             | Net Weight | Grinder   | ES Brewer                | Heating    | Pump            | Milk System |
|--------------|-------|------------------------|------------|-----------|--------------------------|------------|-----------------|-------------|
| <b>JL37A</b> | 3000W | 312(W)*695(H)*608(D)mm | 36kg       | PGH64 x 1 | P22x1/P20/P14 (optional) | Boiler x 2 | Piston pump x 2 | Milk pump   |
| <b>JL37B</b> | 3000W | 312(W)*695(H)*608(D)mm | 33kg       | PGH64 x 1 | P22x1/P20/P14 (optional) | Boiler x 2 | Piston pump x 2 | Milk pump   |
| <b>JL37C</b> | 3000W | 312(W)*695(H)*608(D)mm | 34kg       | PGH64 x 1 | P22x1/P20/P14 (optional) | Boiler x 1 | Piston pump x 2 | —           |
| <b>JL37B</b> | 3000W | 312(W)*695(H)*608(D)mm | 31kg       | PGH64 x 1 | P22x1/P20/P14 (optional) | Boiler x 1 | Piston pump x 2 | —           |

| Screen Type        | Mixer | Bean Hopper | Instant Canister | Steam Wand | Drip Tray                        | Waste Bin                               |
|--------------------|-------|-------------|------------------|------------|----------------------------------|---|
| 10.1" touch screen | 1     | 1700g x 1   | 2L x 2           | Optional   | 1.2L, direct drainage (optional) | 70 cakes direct slagging off (optional) |
| 10.1" touch screen | —     | 1700g x 1   | —                | Optional   | 1.2L, direct drainage (optional) | 70 cakes direct slagging off (optional) |
| 10.1" touch screen | 1     | 1700g x 1   | 2L x 2           | Optional   | 1.2L, direct drainage (optional) | 70 cakes direct slagging off (optional) |
| 10.1" touch screen | —     | 1700g x 1   | —                | Optional   | 1.2L, direct drainage (optional) | 70 cakes direct slagging off (optional) |



# JL38

CQC CE CB

Daily Output:  
**200 Cups**

Colors:



Optional Accessory:  
**Fresh Milk Fridge / Base Cabinet**



### Dual Bean & Grinding System

Two separate hoppers and grinders handle different coffee beans independently, ensuring professional extraction and high efficiency.



### Hot & Cold Fresh Milk Foam

Designed with professional milk pump and dedicated milk frother, delivers hot/cold velvety milk foam.



### Hands-free Auto Cleaning

Purely automated cycles cover rinsing, milk system deep clean, and sanitation—no manual steps required, ensuring hygienic, consistent beverages.



| Model        | Power | Dimensions             | Net Weight | Grinder   | ES Brewer                | Heating    | Pump            | Milk System |
|--------------|-------|------------------------|------------|-----------|--------------------------|------------|-----------------|-------------|
| <b>JL38A</b> | 3000W | 312(W)*695(H)*608(D)mm | 38kg       | PGH64 x 2 | P22x1/P20/P14 (optional) | Boiler x 2 | Piston pump x 2 | Milk pump   |
| <b>JL38B</b> | 3000W | 312(W)*695(H)*608(D)mm | 34kg       | PGH64 x 2 | P22x1/P20/P14 (optional) | Boiler x 2 | Piston pump x 2 | Milk pump   |
| <b>JL38C</b> | 3000W | 312(W)*695(H)*608(D)mm | 36kg       | PGH64 x 2 | P22x1/P20/P14 (optional) | Boiler x 1 | Piston pump x 2 | —           |
| <b>JL38B</b> | 3000W | 312(W)*695(H)*608(D)mm | 32kg       | PGH64 x 2 | P22x1/P20/P14 (optional) | Boiler x 1 | Piston pump x 2 | —           |

| Screen Type        | Mixer | Bean Hopper | Instant Canister | Steam Wand | Drip Tray                        | Waste Bin                               |
|--------------------|-------|-------------|------------------|------------|----------------------------------|---|
| 10.1" touch screen | 1     | 1200g x 2   | 2L x 2           | Optional   | 1.2L, direct drainage (optional) | 70 cakes direct slagging off (optional) |
| 10.1" touch screen | —     | 1200g x 2   | —                | Optional   | 1.2L, direct drainage (optional) | 70 cakes direct slagging off (optional) |
| 10.1" touch screen | 1     | 1200g x 2   | 2L x 2           | Optional   | 1.2L, direct drainage (optional) | 70 cakes direct slagging off (optional) |
| 10.1" touch screen | —     | 1200g x 2   | —                | Optional   | 1.2L, direct drainage (optional) | 70 cakes direct slagging off (optional) |



# JL60A

CQC CE CB

Daily Output:  
**200 Cups**

Colors:  
●

Optional Accessory:  
**Base Cabinet**



# JL60B

CQC CE CB

Daily Output:  
**200 Cups**

Colors:  
●

Optional Accessory:  
**Base Cabinet**



### Dual-Bean, Dual-Grinder

Two 1.8kg bean hoppers paired with twin PGH64 grinders keep different beans separate, delivering consistent, professional extraction.



### Stable, High-Efficiency Water System

A 2700W water boiler and a high-performance gear pump ensure fast recovery with steady temperature and pressure for reliable peak-hour output.



### Powerful Steam Package

A dedicated 1L steam boiler and professional steam wand (JL60A-S3) let you pull espresso and steam milk simultaneously, producing dense, silky microfoam for barista-level drinks.



### Parallel Dual-Menu Brewing

Two menus with twin brewers (JL60B) run concurrently—while one extracts, the other doses and tamps—maximizing throughput during rush periods.

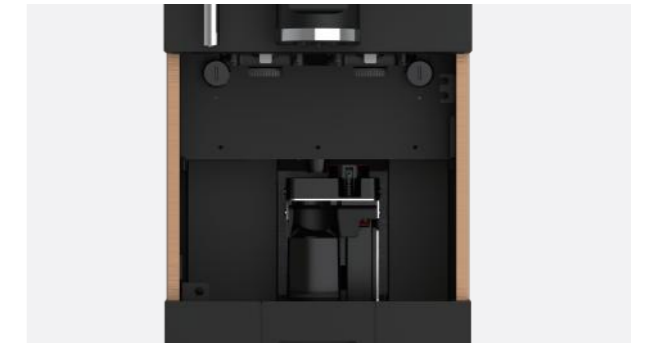

| Model        | Power | Dimensions             | Net Weight | Grinder   | ES Brewer                | Heating    | Pump          |
|--------------|-------|------------------------|------------|-----------|--------------------------|------------|---------------|
| <b>JL60A</b> | 3000W | 315(W)*750(H)*650(D)mm | 47kg       | PGH64 x 2 | P22x1/P20/P14 (optional) | Boiler x 2 | Gear pump x 1 |
| <b>JL60B</b> | 2800W | 315(W)*750(H)*650(D)mm | 48kg       | PGH64 x 2 | P22x2/P20/P14 (optional) | Boiler x 1 | Gear pump x 1 |

| Hot Water Spout | Steam Wand | Screen Type                         | Bean Hopper | Spout Height | Drip Tray                      | Waste Bin                                |
|-----------------|------------|-------------------------------------|-------------|--------------|--------------------------------|--|
| √               | (optional) | 10.1" touch screen                  | 1800g x 2   | 80-180mm     | 1L, direct drainage (optional) | 120 cakes direct slagging off (optional) |
| √               | —          | 10.1" touch screen (parallel menus) | 1800g x 2   | 80-180mm     | 1L, direct drainage (optional) | 120 cakes direct slagging off (optional) |



JL65

CE CB

Daily Output:  
**250 Cups**

Colors:

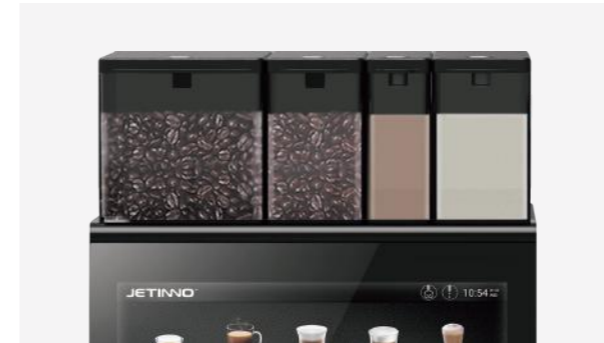
Optional Accessory:  
**Fresh Milk Fridge / Base Cabinet****Dual Grinding & Brewing System**

Dual bean hoppers paired with the high-performance Ditting EMH64 dual grinder and P14/P20 premium brewers, meeting diverse coffee flavor demands with exceptional performance.

**Hot & Cold Milk Frothing**

Featuring the Italian Fluid-o-tech milk pump, which precisely controls the temperature and density of the milk foam, producing fine, smooth hot and cold milk foam to enhance the flavor and quality of fresh milk coffee.

**Diverse Beverage Flavors**

Two large-capacity mix canisters and six groups of syrup offering the flexibility to create a wide variety of flavored drinks, satisfying diverse consumer preferences.

| Model        | Power | Dimensions             | Net Weight | Grinder           | ES Brewer                | Heating    | Pump          | Milk System |
|--------------|-------|------------------------|------------|-------------------|--------------------------|------------|---------------|-------------|
| <b>JL65A</b> | 3100W | 365(W)*730(H)*535(D)mm | 66kg       | Ditting EMH64 x 2 | P14x2/P20/P22 (optional) | Boiler x 2 | Gear pump x 1 | Milk pump   |
| <b>JL65B</b> | 3100W | 365(W)*730(H)*535(D)mm | 58kg       | Ditting EMH64 x 1 | P14x1/P20/P22 (optional) | Boiler x 2 | Gear pump x 1 | Milk pump   |

| Screen Type      | Mixer | Bean Hopper   | Instant Canister   | Syrup                | Drip Tray                      | Waste Bin                                  |
|------------------|-------|---------------|--------------------|----------------------|--------------------------------|--|
| 14" touch screen | 1     | 5Lx 1+2.8Lx 1 | 2.3L x 1 +3.5L x 1 | Optional<br>6 groups | 1L, direct drainage (optional) | 80 cakes<br>direct slagging off (optional) |
| 14" touch screen | 2     | 5Lx 1         | 2.3L x 1 +3.5L x 2 | Optional<br>6 groups | 1L, direct drainage (optional) | 80 cakes<br>direct slagging off (optional) |



Delivering exceptional coffee flavor and a diverse selection of beverages. Equipped with an intelligent self-service system, it features automatic cup dispensing, remote management, and multiple payment options. Designed for efficiency and personalization, it redefines modern beverage consumption.



# JL28

CE CB

Daily Output:  
**200 Cups**

Colors:  
● ●

Optional Accessory:  
**Base Cabinet**



# JL40

CE CB

Daily Output:  
**200 Cups**

Colors:  
●

Optional Accessory:  
**Base Cabinet**

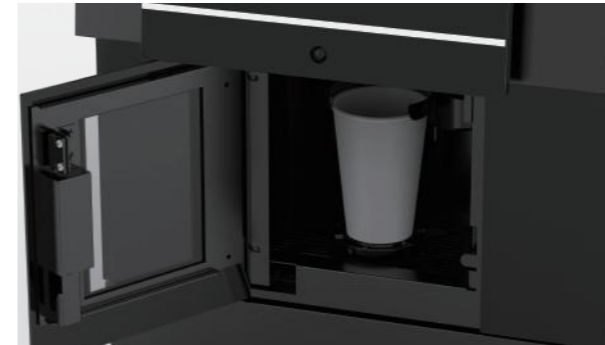

### Built-in Cup Dispenser

Stores up to 75 cups, with an intelligent automatic cup dispensing system, eliminating the need for manual cup retrieval. This saves time and reduces potential contamination.



### Multi-Canister Design

Equipped with four instant canisters, capable of preparing over 10 types of coffee and instant beverages, including classic coffee, milk-based drinks, and juice—perfect for catering to diverse taste preferences.



### Exceptional Performance & Stability

Features a 2700W high-efficiency storage boiler, combined with a precision gear pump to ensure stable temperature and pressure output. Its strong refilling capability meets high-demand usage, providing a seamless and reliable experience.



| Model       | Power | Dimensions             | Net Weight | Grinder   | ES Brewer                | Heating    | Pump          |
|-------------|-------|------------------------|------------|-----------|--------------------------|------------|---------------|
| <b>JL28</b> | 3000W | 420(W)*800(H)*660(D)mm | 60kg       | PGH64 x 1 | P14x1/P20/P22 (optional) | Boiler x 1 | Gear pump x 1 |
| <b>JL40</b> | 2700W | 420(W)*805(H)*650(D)mm | 60kg       | PGH64 x 1 | P20x1/P14/P22 (optional) | Boiler x 1 | Gear pump x 1 |

| Cup Delivery Door        | Cup Number | Bean Hopper | Instant Canister | Drip Tray                        | Waste Bin                                |
|--------------------------|------------|-------------|------------------|----------------------------------|--|
| Manual cup delivery door | 75         | 1.5kg x 1   | 2L x 2+ 1.5L x 2 | 1.5L, direct drainage (optional) | 130 cakes direct slagging off (optional) |
| Manual cup delivery door | 75         | 1.5kg x 1   | 3L x 2+ 2L x 2   | 1.5L, direct drainage (optional) | 130 cakes direct slagging off (optional) |



# JL220

CQC CE CB

Daily Output:  
**200 Cups**

Colors:  
●



### Compact Design with Smart Features

Equipped with a 14-inch vertical screen and PIR motion-sensing technology for an intuitive and smart user experience. With a footprint of just 0.35m<sup>2</sup>, it is ideal for compact office or commercial spaces.



### Diverse Beverage Options

Features 1 bean hopper and 5 instant mix canisters, offering 20+ beverage choices to cater to various taste preferences.



### Effortless Maintenance

Multiple automatic cleaning options, advanced intelligent detection, and IoT backend management simplify maintenance, allowing for a hassle-free and efficient operation.

| Model        | Power | Dimensions              | Net Weight | Grinder   | ES Brewer                | Heating    | Pump            |
|--------------|-------|-------------------------|------------|-----------|--------------------------|------------|-----------------|
| <b>JL220</b> | 2600W | 500(W)*1675(H)*700(D)mm | 100kg      | PGH64 x 1 | P20x1/P14/P22 (optional) | Boiler x 1 | Piston pump x 1 |

| Cup Delivery Door | Cup Number | Lid Number | Cup Specifications | Bean Hopper | Instant Canister | Drip Tray | Waste Bin |
|-------------------|------------|------------|--------------------|-------------|------------------|-----------|-----------|
| Cup Delivery Door | 120        | 90         | D80mm, 10 Oz       | 1.8kg x1    | 4L x 2+ 2L x 3   | 15L       | 130 cakes |



# JL300

CQC CE CB

Daily Output:  
**150 Cups**

Colors:  
● ●

Optional Accessory:  
**BIB / Top Light Box**



### Built-in Cup Dispenser

Stores up to 150 cups with an intelligent automatic cup dispensing system, enabling a fully self-service experience. From bean to cup, enjoy fresh coffee with just one touch.



### Immersive Self-Service Experience

Transparent bean hopper design provides a clear view of the grinding process. Features automatic cup dispensing, automatic lift door, manual lid dispenser, and a packaging shelf, enhancing the overall coffee purchase experience.



### Powerful Backend Management

Integrated with the advanced SaaS coffee machine management platform, supporting remote bulk operations and management of coffee machines. Enables real-time monitoring and data analysis, optimizing operations and ensuring full control over each machine's performance.

| Model               | Power | Dimensions              | Net Weight | Grinder   | ES Brewer                | Filter Brewer | Heating    | Pump            |
|---------------------|-------|-------------------------|------------|-----------|--------------------------|---------------|------------|-----------------|
| <b>JL300-ES7C</b>   | 2800W | 664(W)*1855(H)*720(D)mm | 150kg      | PGH64 x 1 | P14x1/P20/P22 (optional) | —             | Boiler x 1 | Piston pump x 1 |
| <b>JL300-ESFB7C</b> | 2800W | 664(W)*1855(H)*720(D)mm | 150kg      | PGH64 x 1 | P14x1/P20/P22 (optional) | 14g x 1(tea)  | Boiler x 1 | Piston pump x 1 |
| <b>JL300-IN8C</b>   | 2800W | 664(W)*1855(H)*720(D)mm | 150kg      | —         | —                        | —             | Boiler x 1 | Piston pump x 1 |

| Cup Delivery Door | Cup Number | Lid Number | Cup Specifications              | Bean Hopper | Instant Canister | Drip Tray | Waste Bin |
|-------------------|------------|------------|---------------------------------|-------------|------------------|-----------|-----------|
| Cup Delivery Door | 150        | 85         | D90mm, 12 Oz<br>16 Oz(optional) | 1.8kg x1    | 4L x 6           | 20L       | 140 cakes |
| Cup Delivery Door | 150        | 85         | D90mm, 12 Oz<br>16 Oz(optional) | 1.8kg x1    | 4L x 6           | 20L       | 140 cakes |
| Cup Delivery Door | 150        | 85         | D90mm, 12 Oz<br>16 Oz(optional) | —           | 4L x 8           | 20L       | —         |



# JL320

CQC CE CB

Daily Output:  
**200 Cups**

Colors:  
●

Optional Accessory:  
**BIB / Top Light Box**

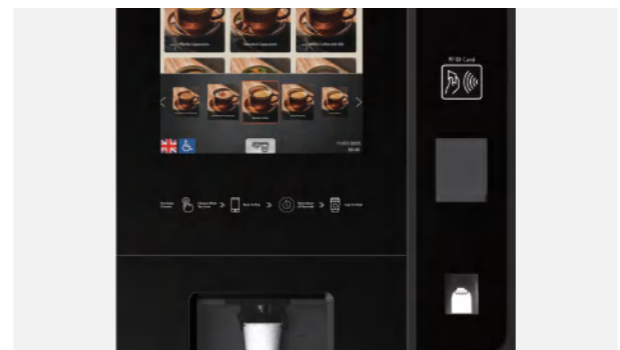

**Mega Capacity & Versatility**

Single 4.8kg or dual setup (4.8kg + 2.8kg) of bean hopper and 5-6 instant powder canisters with optional 4.5L and 7L capacity.



**Dry-Sugar-to-Cup & Stirrer Dispensing**

Direct dry sugar-to-cup and automatic stirring rod dispensing eliminates manual steps while ensuring served-ready consistency.



**Multiple Payment Options**

Supports various payment methods including cards, coins, QR code, EXE and MDB protocols, making transactions convenient and secure.

| Model         | Power | Dimensions              | Net Weight | Grinder   | ES Brewer                | Mixer | Heating    | Pump            |
|---------------|-------|-------------------------|------------|-----------|--------------------------|-------|------------|-----------------|
| <b>JL320A</b> | 3000W | 664(W)*1830(H)*740(D)mm | 150kg      | PGH64 x 1 | P14x1/P20/P22 (optional) | 4     | Boiler x 1 | Piston pump x 1 |
| <b>JL320B</b> | 3000W | 664(W)*1830(H)*740(D)mm | 150kg      | PGH64 x 2 | P14x1/P20/P22 (optional) | 3     | Boiler x 1 | Piston pump x 1 |

| Cup Number | Cup Specifications | Bean Hopper           | Instant Canister  | Sugar canister on door | Stirrer | Drip Tray | Waste Bin |
|------------|--------------------|-----------------------|-------------------|------------------------|---------|-----------|-----------|
| 600        | D70mm, 6 Oz        | 4.8kg x 1             | 4.5L x 4 + 7L x 2 | 4.5L x 1               | 500 pcs | 20L       | 600 cakes |
| 600        | D70mm, 6 Oz        | 4.8kg x 1 + 2.8kg x 1 | 4.5L x 4 + 7L x 1 | 4.5L x 1               | 500 pcs | 20L       | 600 cakes |



# JL500

CQC CE CB

Daily Output:  
**250 Cups**

Colors:  
●

Optional Accessory:  
**BIB / Top Light Box**



### High-Performance Brewing System

Equipped with a high-performance P14 brewer (optional P20) and a 2700W boiler and powerful gear pump, ensuring efficient and stable 9-bar pressure and 92°C optimal extraction for premium coffee quality.



### 20+ Hot & Cold Beverage Options

Features a multi-canister design with a built-in chiller, capable of preparing over 20 types of hot and cold coffee and instant beverages.



### 27-Inch Touchscreen

Sleek and modern design with an intuitive 27-inch touchscreen for effortless operation provides a seamless and convenient coffee experience.

| Model                  | Power | Dimensions              | Net Weight | Grinder          | ES Brewer                | Filter Brewer | Heating    | Pump            |
|------------------------|-------|-------------------------|------------|------------------|--------------------------|---------------|------------|-----------------|
| <b>JL500-ES7C-PI</b>   | 2700W | 664(W)*1855(H)*720(D)mm | 150kg      | Ditting EMH64 x1 | P14x1/P20/P22 (optional) | —             | Boiler x 1 | Gear pump x 1   |
| <b>JL500-ESFB7C-PI</b> | 2700W | 664(W)*1855(H)*720(D)mm | 150kg      | Ditting EMH64 x1 | P14x1/P20/P22 (optional) | 14g x 1(tea)  | Boiler x 1 | Gear pump x 1   |
| <b>JL500-IN8C-PI</b>   | 2700W | 664(W)*1855(H)*720(D)mm | 150kg      | —                | —                        | —             | Boiler x 1 | Piston pump x 1 |

| Cup Delivery Door        | Cup Number | Lid Number          | Cup Specifications                  | Bean Hopper | Instant Canister | Drip Tray | Waste Bin |
|--------------------------|------------|---------------------|-------------------------------------|-------------|------------------|-----------|-----------|
| Manual cup delivery door | 150-200    | 130 (90mm) optional | D80mm, 10Oz<br>90mm, 12Oz(optional) | 1.5kg x 1   | 4L x 6           | 15L       | 125 cakes |
| Manual cup delivery door | 150-200    | 130 (90mm) optional | D80mm, 10Oz<br>90mm, 12Oz(optional) | 1.5kg x 1   | 4L x 6           | 15L       | 125 cakes |
| Manual cup delivery door | 150-200    | 130 (90mm) optional | D80mm, 10Oz<br>90mm, 12Oz(optional) | —           | 4L x 8           | 15L       | —         |



# JL550

CQC CE CB

Daily Output:  
**250 Cups**

Colors:  
●

Optional Accessory:  
**BIB / Top Light Box**



### Ditting Grinder

Features the Swiss Ditting EK7 grinder with 64mm flat burrs for even grinding. Made of impact-resistant special steel, it offers multi-stage grind size adjustment to meet various brewing needs.



### Built-in Ice Maker

Equipped with powerful compressor and evaporator, this integrated system combines ice production and chilled water functions. With precise ice output control and a 1.5kg ice storage capacity, it ensures a continuous supply of ice for high-demand scenarios.



### 40 Hot & Cold Beverage Options

Featuring a multi-canister design with the option for a tea brewing function, capable of producing over 40 types of hot and cold beverages, providing a one-stop beverage solution with a diverse selection to meet varying taste preferences.

| Model                  | Power | Dimensions               | Net Weight | Grinder         | ES Brewer                | Filter Brewer | Heating    | Pump          |
|------------------------|-------|--------------------------|------------|-----------------|--------------------------|---------------|------------|---------------|
| <b>JL550-ES7C-PI</b>   | 3300W | 1000(W)*1855(H)*785(D)mm | 280kg      | Ditting EK7 x 1 | P14x1/P20/P22 (optional) | —             | Boiler x 1 | Gear pump x 1 |
| <b>JL550-ESFB7C-PI</b> | 3300W | 1000(W)*1855(H)*785(D)mm | 280kg      | Ditting EK7 x 1 | P14x1/P20/P22 (optional) | 14g x 1 (tea) | Boiler x 1 | Gear pump x 1 |

| Cup Delivery Door | Cup Number | Lid Number | Cup Specifications              | Bean Hopper | Instant Canister | Drip Tray                         | Waste Bin |
|-------------------|------------|------------|---------------------------------|-------------|------------------|-----------------------------------|-----------|
| Cup Delivery Door | 150        | 130        | D90mm, 12 Oz<br>16 Oz(optional) | 1.5kg x 1   | 4L x 6           | 15L<br>direct drainage (optional) | 125 cakes |
| Cup Delivery Door | 150        | 130        | D90mm, 12 Oz<br>16 Oz(optional) | 1.5kg x 1   | 4L x 6           | 15L<br>direct drainage (optional) | 125 cakes |



# JL580

CQC CE CB

Daily Output:  
**200 Cups**

Colors:  
● ○

Optional Accessory:  
**Top Light Box**



**32" Touchscreen with Ambiance Lighting**

Ultra-large display ensures crystal-clear menu visibility, while perimeter lighting provides dynamic status cues and elevates aesthetic appeal.



**Dual Auto-Cup Dispensing**

Automatically selects the optimal cup type (paper for hot drinks, plastic for cold drinks), with real-time cup inventory monitoring to prevent service interruptions.



**Comprehensive Ingredient Hub**

2 bean hoppers, 4 powder canisters, 4 BIBs, 4 syrup lines, and built-in ice maker integrated with cold water and carbonated water modules support limitless beverage combinations.

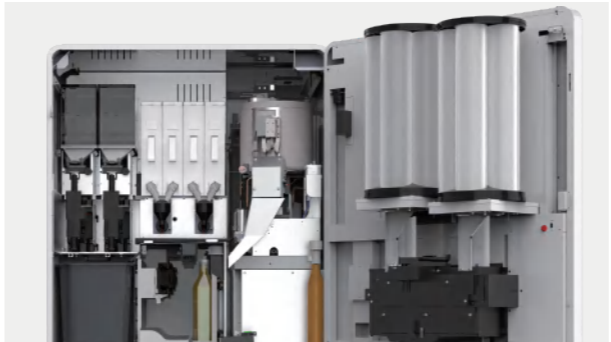

| Model                   | Power | Dimensions               | Net Weight | Grinder   | ES Brewer                | Mixer | Heating    | Pump          | Carbonated Water | Syrup    | BIB      | Cup Number | Cup Size   | Bean Hopper | Instant Canister | Drip Tray                         | Waste Bin |
|-------------------------|-------|--------------------------|------------|-----------|--------------------------|-------|------------|---------------|------------------|----------|----------|------------|--|-------------|------------------|-----------------------------------|-----------|
| <b>JL580-ESLC6C4B4S</b> | 3400W | 1000(W)*1870(H)*800(D)mm | 280kg      | PGH64 x 2 | P14x2/P20/P22 (optional) | 2     | Boiler x 1 | Gear pump x 1 | Support          | 4 groups | 4 groups | 220+200    | D92mm, 20 Oz, transparent cup<br>D90mm, 20 Oz, paper cup | 1.8kg x2    | 4L x 4           | 20L<br>direct drainage (optional) | 15L       |



Enjoy a seamless self-service experience with diverse coffee flavors. Automatic cup dispensing and lid sealing ensure a touch-free, grab-and-go convenience. Smart management and remote operation make high-quality coffee service effortless and efficient.



# JL510

CQC CE CB

Daily Output:  
**250 Cups**

Colors:



Optional Accessory:  
**BIB / Top Light Box**



### Automatic Cup Dispensing & Lid Capping

Automatic cup dispensing and lid capping, with smart alerts for low cups/lids and missing cups/lids, improving operational speed and efficiency.



### Automatic Cleaning

Allows for scheduled automatic cleaning of the entire machine or specific components, reducing the risk of residue in the system and enhancing beverage hygiene and safety.



### Remote Cloud Monitoring

Enables real-time monitoring of equipment status via mobile or computer, including ingredient consumption, beverage sales, and troubleshooting, lower the work for on-site staff.

| Model                    | Power | Dimensions              | Net Weight | Grinder          | ES Brewer                | Filter Brewer | Heating    | Pump            |
|--------------------------|-------|-------------------------|------------|------------------|--------------------------|---------------|------------|-----------------|
| <b>JL510-ES7C-PI-Y</b>   | 2700W | 664(W)*1855(H)*720(D)mm | 150kg      | Ditting EMH64 x1 | P14x1/P20/P22 (optional) | —             | Boiler x 1 | Gear pump x 1   |
| <b>JL510-ESFB7C-PI-Y</b> | 2700W | 664(W)*1855(H)*720(D)mm | 150kg      | Ditting EMH64 x1 | P14x1/P20/P22 (optional) | 14g x 1(tea)  | Boiler x 1 | Gear pump x 1   |
| <b>JL510-IN8C-PI-Y</b>   | 2700W | 664(W)*1855(H)*720(D)mm | 150kg      | —                | —                        | —             | Boiler x 1 | Piston pump x 1 |

| Cup Delivery Door        | Cup Number | Lid Number | Cup Specifications | Bean Hopper | Instant Canister | Drip Tray | Waste Bin |
|--------------------------|------------|------------|--------------------|-------------|------------------|-----------|-----------|
| Manual cup delivery door | 150        | 130        | D90mm, 16 Oz       | 1.5kg x 1   | 4L x 6           | 15L       | 125 cakes |
| Manual cup delivery door | 150        | 130        | D90mm, 16 Oz       | 1.5kg x 1   | 4L x 6           | 15L       | 125 cakes |
| Manual cup delivery door | 150        | 130        | D90mm, 16 Oz       | —           | 4L x 8           | 15L       | —         |



JL560

CQC CE CB

Daily Output:  
**250 Cups**

Colors:



Optional Accessory:  
**BIB / Top Light Box**

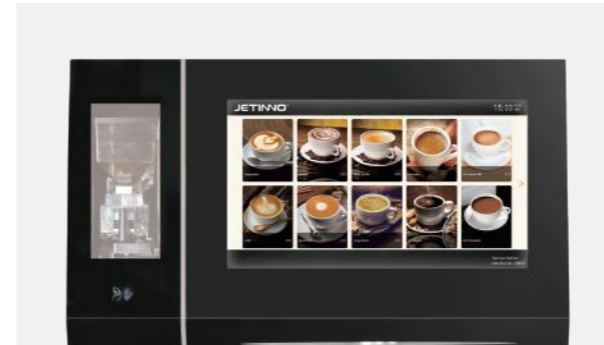

**Grab & Go Contactless Experience**

One-touch activation for automatic cup dispensing, cup placement, lid capping, and automatic lift door—fully automated operation, providing a completely contactless beverage experience.



**Standardized Ice Beverage Output**

Precise control over ice output and continuous ice production, ensuring each cup of iced coffee meets consistent standards and can handle high-volume demand during peak hours.



**Visible Freshly Ground Coffee**

The transparent glass panel in front of the coffee bean hopper and grinder allow customers to see the coffee beans being freshly ground, enhancing the sensory experience as they enjoy the rich aroma of every cup.

| Model                    | Power | Dimensions               | Net Weight | Grinder         | ES Brewer                | Filter Brewer | Heating    | Pump          |
|--------------------------|-------|--------------------------|------------|-----------------|--------------------------|---------------|------------|---------------|
| <b>JL560-ES7C-PI-Y</b>   | 3200W | 1000(W)*1855(H)*785(D)mm | 280kg      | Ditting EK7 x 1 | P14x1/P20/P22 (optional) | —             | Boiler x 1 | Gear pump x 1 |
| <b>JL560-ESFB7C-PI-Y</b> | 3200W | 1000(W)*1855(H)*785(D)mm | 280kg      | Ditting EK7 x 1 | P14x1/P20/P22 (optional) | 14g x 1 (tea) | Boiler x 1 | Gear pump x 1 |

| Cup Delivery Door | Cup Number | Lid Number | Cup Specifications | Bean Hopper | Instant Canister | Drip Tray                      | Waste Bin |
|-------------------|------------|------------|--------------------|-------------|------------------|--------------------------------|-----------|
| Cup Delivery Door | 150        | 130        | D90mm, 16 Oz       | 1.5kg x 1   | 4L x 6           | 15L direct drainage (optional) | 125 cakes |
| Cup Delivery Door | 150        | 130        | D90mm, 16 Oz       | 1.5kg x 1   | 4L x 6           | 15L direct drainage (optional) | 125 cakes |



JL852

CQC CE CB

Daily Output:  
**300 Cups**

Colors:



Optional Accessory:  
**BIB / Top Light Box**



**Integrated Ice and Chilled Water System**

Powerful ice making and storage capabilities, combined with instant cold water dispensing, ensuring efficient preparation of iced and chilled beverages.



**Triple Boiler & Dual Pump System**

Enhances both coffee extraction and milk frothing efficiency, while also improving the quality of fresh milk coffee. The dual systems work simultaneously to reduce customer wait time.



**Smart Hot & Cold Fresh Milk Frothing**

Professional milk pumps provide the foundation for producing thick, smooth hot and cold milk foam, supporting three different types of fresh milk to meet diverse consumer preferences.



**Flavor Syrup Module**

Supports 6 different syrup flavors, unlocking the potential for flavored coffee options. The intelligent syrup dispensing system allows for precise control of sweetness levels, satisfying a variety of taste preferences.



| Model                      | Power | Dimensions                | Net Weight | Grinder                              | ES Brewer                   | Filter Brewer | Heating    | Pump          |
|----------------------------|-------|---------------------------|------------|--------------------------------------|-----------------------------|---------------|------------|---------------|
| <b>JL852-ESFB7C6S-FM-Y</b> | 3800W | 1000(W)*1900(H)*1000(D)mm | 450kg      | Ditting EMH64 x1<br>PGH64 (optional) | P14x1/P20/P22<br>(optional) | 14g x 1(tea)  | Boiler x 3 | Vane pump x 1 |

| Cup Delivery Door | Cup Number | Lid Number | Cup Size                 | Bean Hopper | Instant Canister | Drip Tray                         | Waste Bin |
|-------------------|------------|------------|--------------------------|-------------|------------------|-----------------------------------|-----------|
| Cup Delivery Door | 150        | 130        | D90mm, 16 Oz, Opt. 12 Oz | 1.8kg x1    | 4L x 6           | 20L<br>direct drainage (optional) | 125 cakes |

# ACCESSORIES



## JA10 Automatic Cup Dispenser

Dimensions: 330(W)\*840(H)\*690(D)mm  
 Net Weight: 30kg  
 Power Supply: Host-powered (by coffee machine)  
 Interface: Coffee machine command  
 Communication: RS485  
 Cup Dispenser: 5-column dispenser \*2  
 Cup Specs: Paper/ plastic, D80mm/ D90mm  
 Capacity: Max 155 paper & 112 plastic



## JA30 Ice Maker

Dimensions: 320(W)\*680(H)\*680(D)mm  
 Net Weight: 57.5kg/55kg  
 Power Supply: AC220V~50/60HZ, 600W  
 Water Supply: Tap water  
 Coolant: R290  
 Capacity: No less than 72kg/day  
 Ice Bucket Volume: 1.5kg/4kg  
 Ice Cube: Nugget, about 1.2g/pcs  
 Mode: Standalone Mode/ Connected Mode

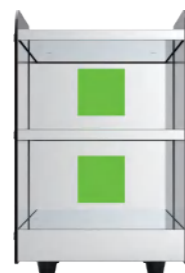

## JA15 Cup Warmer

Dimensions: 320(W)\*500(H)\*400(D)mm  
 Net Weight: 15kg  
 Power Supply: AC 100V-240V, 50Hz/60Hz, 105W  
 Heating Method: PI film heating  
 Temperature Control Range: Approx. 60°C  
 Heating Layers: 3  
 Capacity: Approx. 30 cups (depending on cup size)



## JA16 Cup Dispenser

Dimensions: 155(W)\*570(H)\*400(D)mm  
 Net Weight: 8.5kg  
 Cup Bucket: 3  
 Cup Diameter: 72mm/80mm/89mm, customizable  
 Cup Height: No special requirements  
 Capacity: Approx. 50 cups/bucket\*3  
 Cup Material: Paper, thick plastic  
 Retrieval Method: Manual



## JA19 Commercial Milk Steamer

Dimensions: 261(W)\*607(H)\*462(D)mm  
 Net Weight: 21kg  
 Power Supply: 220-240V, 50/60Hz, 3500W  
 Water Supply: Direct water, barreled water  
 Hot Water Spout: Yes  
 Steam Wand: Yes  
 Pump: Water pump\*1, air pump\*1  
 Water Boiler: 8.5L, 3000W  
 Steam Boiler: 5.5L, 2000W  
 Interface: 7" touch screen  
 Output Capacity: 110 Cups/Hour



## JA20 Automatic Milk Frother

Dimensions: 261(W)\*607(H)\*462(D)mm  
 Net Weight: 20kg  
 Power Supply: 220-240V 50/60Hz, 3100W  
 Water Supply: Direct water, barreled water  
 Pump: Piston pump\*1/ gear pump\*1  
 Steam Boiler: 0.7L, 3000W  
 Spout Height: 80-185mm (adjustable)  
 Interface: 7" touch screen  
 Milk Module: 3 milk sources, hot/ cold foam  
 Output Capacity: 300 cups/hour



**JA04 Syrup Module**

Dimension: 260 mm(W)\* 600mm(H)\*x 426mm(D)  
 Net Weight: 21kg  
 Rated Power: 52W  
 Syrup Capacity: 4 bottles  
 Noise: Sound power level≤65dB(A)  
 Compatible Model(s): JL38



**JA06 Syrup Module**

Dimension: 260 mm(W)\* 600mm(H)\*x 426mm(D)  
 Net Weight: 21kg  
 Rated Power: 78W  
 Syrup Capacity: 6 bottles  
 Noise: Sound power level≤65dB(A)  
 Compatible Model(s): JL65



**JMC01 Milk Tank**

Capacity: 500ml  
 Height: 170mm  
 Diameter: 85mm  
 Weight: 159.4g



**JMC06 Milk Fridge**

Voltage/Frequency: 220-240V 50/60Hz  
 Power: 48W  
 Temperature Range: 0~4°C  
 Refrigerant: R600a  
 Milk Box Capacity: 3.8L  
 Effective Volume: 6.5L  
 Packaging dimension: 286(W)\*475(H)\*482(D)mm  
 Outside dimension: 220(W)\*400(H)\*402(D)mm  
 Weight: 11kg  
 Milk Position Alert: Yes



**JMC09 Milk Fridge**

Voltage/Frequency: 220-240V 50/60Hz  
 Power: 60W  
 Temperature Range: 0~4°C  
 Refrigerant: R600a  
 Milk Box Capacity: 4L  
 Effective Volume: 8.5L  
 Packaging dimension: 290(W)\*530(H)\*525(D)mm  
 Outside dimension: 220(W)\*456(H)\*452(D)mm  
 Weight: 14.1kg  
 Milk Position Alert: Yes



**JMC16 Milk Fridge**

Voltage/Frequency: 220-240V 50/60Hz  
 Power: 60W  
 Temperature Range: 0~4°C  
 Refrigerant: R600a  
 Milk Box Capacity: 2 x 4.5L  
 Effective Volume: 16L  
 Packaging dimension: 315(W)\*530(H)\*665(D)mm  
 Outside dimension: 240(W)\*450(H)\*615(D)mm  
 Weight: 16kg  
 Milk Position Alert: Yes